

Product information

No. 34205000

KAJO-Adhesive Oil for Saw Chains BIO 2050

EU Ecolabel: DE/027/001



KAJO- Adhesive Oil for Saw Chains BIO 2050 is made from specially treated vegetable oils. These vegetable oils contain additives based on natural raw materials which improve the behaviour in the mixed friction area. Due to shear stable additives a good lubrication at high chain speeds is guaranteed.

Practical advantages:

KAJO-BIO 2050 Adhesive Oil for Saw Chains is used for lubricating fast running motor and electric saws for all types of woods.

Furthermore, our **KAJO-BIO 2050 Adhesive Oil for Saw Chains** is especially suitable for lubrication of slide ways and chain block devices during wood transport. Due to its outstanding lubricating properties and its adhesiveness it remains at the lubricating point and leads to the reduction of the coefficients of friction and wear. Additionally, the addition with anti-oxidants leads to prolonged service life (see aging).

Environment:

KAJO-BIO 2050 Adhesive Oil for Saw Chains is 100 % biodegradable. The radio carbon method C 14 according to ASTM D 6866 impressively proves this.

When used properly, it is toxicologically recognized as safe and practically harmless to surface and groundwater, as it is completely and easily biodegradable.

KAJO-BIO 2050 Adhesive Oil for Saw Chains

meets the requirements of the

- a) Federal Environmental Agency
- b) service ability (KWF)

and is entitled to carry the eco-label „Blauer Engel“ according to RAL-UZ 178.

Furthermore, it is entitled with the European Ecolabel, reg.-no. DE/027/001. This regulation stipulates, apart from the technical requirements, the part of the renewable raw materials.

Product information
No.34205000

KAJO-Adhesive Oil for Saw Chains BIO 2050

Typical characteristics:

Properties	Value	Unit	Standard
Colour (ASTM)	3		ASTM D 1500
Viscosity at 20 °C at 40 °C at 100 °C	117 52 11,6	mm ² /s	DIN EN ISO 3104
Viscosity index (VI)	225		DIN ISO 2909
Density at 20 °C	920	kg/m ³	DIN EN ISO 12 185
Flash point COC	>300	°C	DIN EN ISO 2592
Pourpoint	-27	°C	ASTM D 97
VKA o.k. / welding load	2000/2200	N	DIN 51 350
Stringiness acc. to KHM	130	mm	KHM 006
Load capacity acc. to Brugger	40	N/mm ²	DIN 51 347
Minimum requirements acc. to KWF	27	N/mm ²	
Part of renewable raw materials	100	%	ASTM D 6866 Radio Carbon Method C ¹⁴

Flow behaviour with cold:

Fresh oil	1	sec.	
Low temperature storage -15 °C / 168 h	1	sec.	
Minimum requirements acc. to KWF	<15	sec.	

Aging:

Test method acc. to KWF Heating in glass dish 80 °C			
Flow time fresh oil	2	sec.	
Flow time after 120 h	2		
Flow time after 240 h	2		
Flow time after 1000 h			
Flow time after 4500 h	<15	sec	
Minimum requirement after 1000 h	<15 above initial flow time	sec.	

Version 3 revised: 11.02.2015 DR/MJ/Pos./AO

All ratings are average values and are subject to production-related variations.

Product information
No. 34205000

KAJO-Adhesive Oil for Saw Chains BIO 2050

Determination of flow behaviour when cold

1. Devices:

Cold chamber, temperature adjustment up to $-30\text{ }^{\circ}\text{C}$ (243 K)
 Pour point vessel with an additional marking according to the drawing
 Thermometer
 Stop watch

2. Procedure:

The appropriate pour-point vessel is filled with the oil sample up to the first mark. Then it is stored without cover in the cold chamber at $-15\text{ }^{\circ}\text{C}$ (258 k). After 168 hours of cooling, the test vessel is taken out and turned immediately by 90° from the vertical into the horizontal position. Measure the time until the oil reaches the second marking.

3. Minimum requirement:

flow time in the measuring area < 15 sec.

pour point jar according to DIN ISO 3016

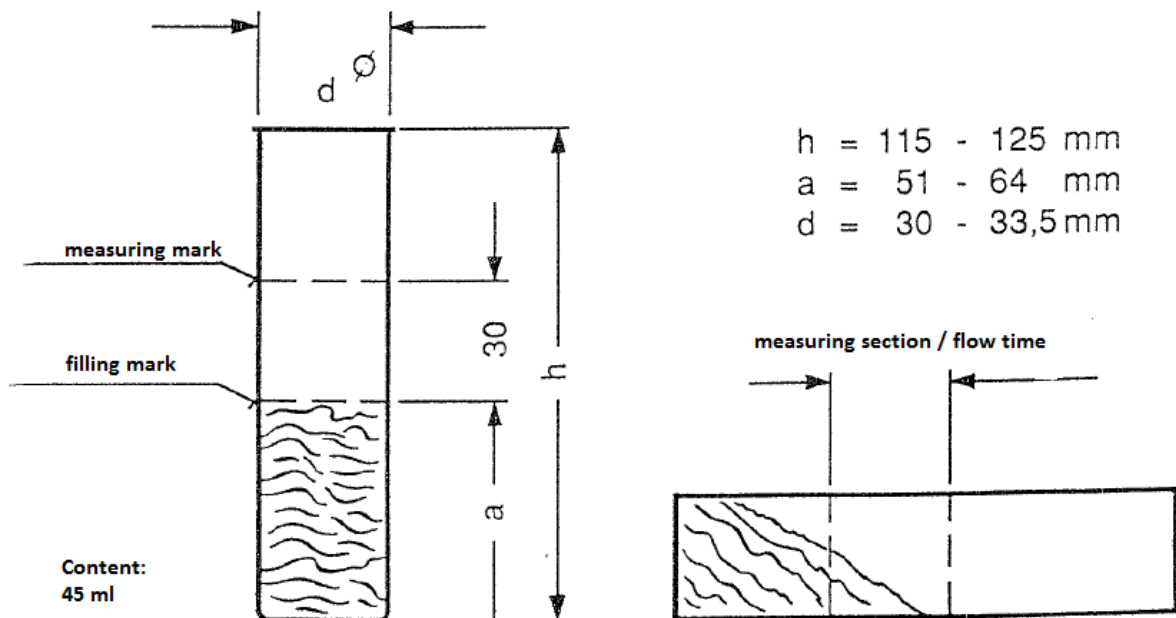

Appendix 1

Product information

No. 34205000

KAJO-Adhesive Oil for Saw Chains BIO 2050

Determination of aging behaviour

1. Devices:

Heating cabinet with an adjustable temperature between 50° C and 100° C (323 K – 373 K).
 Petri dishes with 90 mm diameter with marking according to the drawing.
 Device for holding the petri dishes.
 Stop watch.

2. Procedure:

6 grams of the oil sample are filled into the clean Petri dishes. Then these are stored in the heating cabinet at a temperature of 80° C, without circulating air. After a heating period of 1.000 hours, the test dish is taken out and cooled down to room temperature (20° C ± 2° C). Thereafter the flow time is determined by arranging the dishes on a device at an inclined position of 25°. Measure the time until the oil reaches the marking.

Each test is made with 3 test dishes. Each test dish is measured five times, each time it is turned by 72°. The measurements are taken at intervals of 10 minutes.

3. Minimum requirements:

Flow time in the measuring area < 15 sec. above initial flow time.

